

# WATER PUMP CATALOGUE

## TRUCK & BUS SECTION

### ALL MAKES



SINERT



# SP

## WATER PUMPS

WEB EDITION

S.P. WATER PUMPS LTD

18 Tatton Court, Kingsland Grange, Woolston,  
Warrington, Cheshire. ENGLAND. WAI 4RR

TEL: +44(0)1925 850082 FAX: +44(0)1925 850083

Email:sales@spwaterpumps.co.uk Web Site:www.spwaterpumps.co.uk

## LEYLAND

**SP1589**

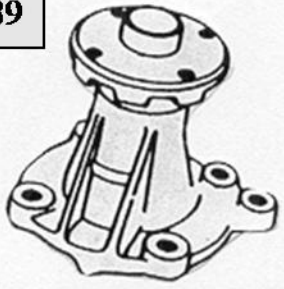

BLMC 3.8 Leyland Roadrunner

**SP1590**

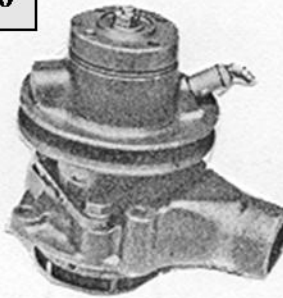

Nuffield Tractor 5.1, 5.7 Litre Early Version

**SP1591**

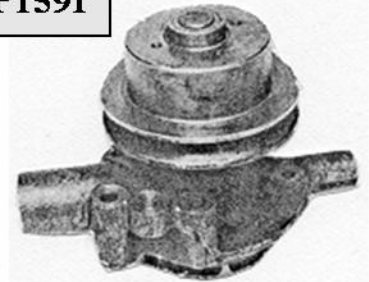

Nuffield Tractor 5.1, 5.7 Litre Late Version

**SP1592**

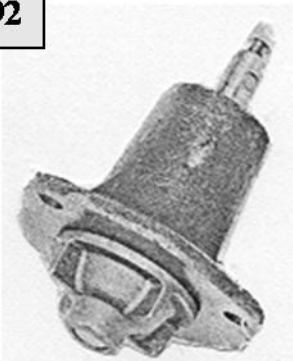

LEYLAND 20 CWT Slotted Shaft

**SP1594**

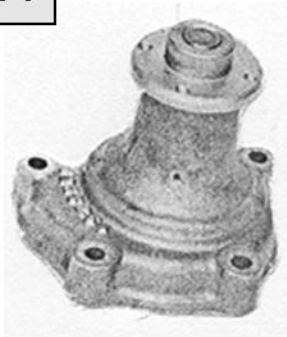

LEYLAND 154

**SP1600**

LEYLAND 350

**SP1601**

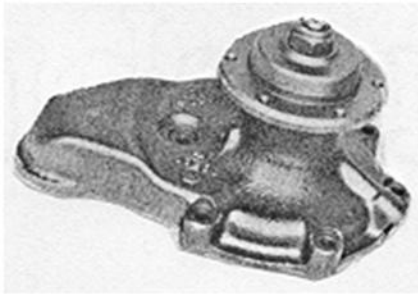

LEYLAND 400

**SP1603**

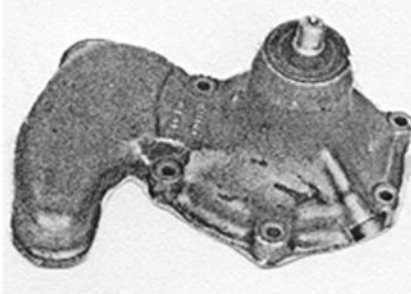

LEYLAND 401

**SP1605**

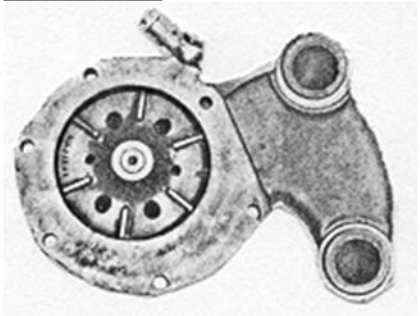

LEYLAND 402

**SP1607**

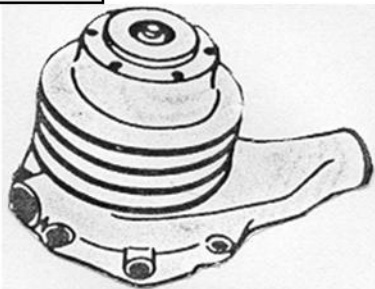

LEYLAND 410

**SP1609**

Large Oil Seal fitted

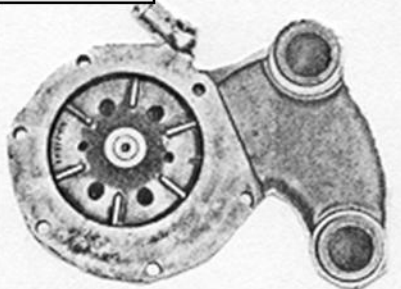

LEYLAND 411 / 420 Freighter

**SP1611**

LEYLAND T45 Roadtrain



## LEYLAND

**SP1616**

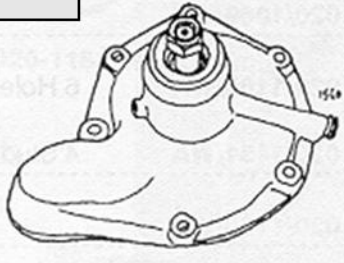

LEYLAND 680

**SP1618**

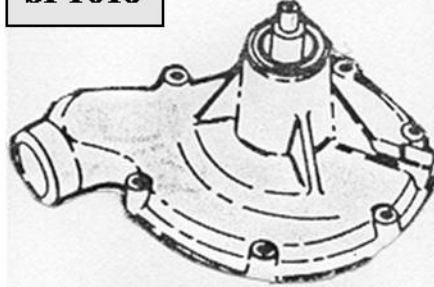

LEYLAND TL11 Olympian Pipe Fitting

**SP1620**

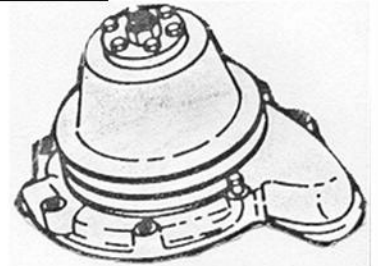

LEYLAND TL11 Octopus O/Ring Fitting

**SP1622**

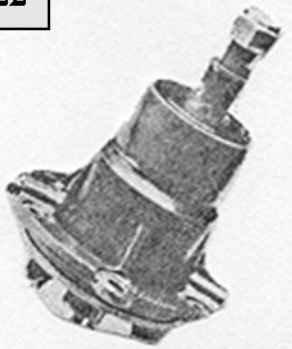

LEYLAND TL12 Buffalo

**SP1624**

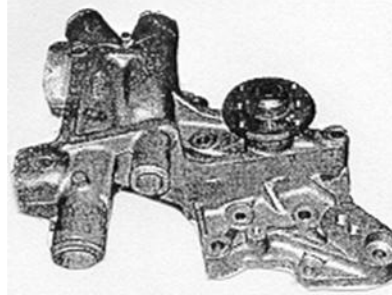

MONTEGO Diesel Turbo

**SP1625**

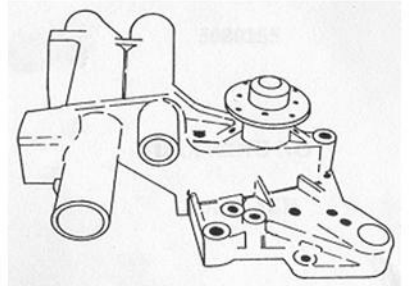

MONTEGO Diesel Turbo

**SP1630**

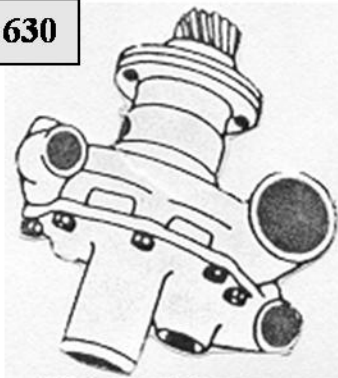

LEYLAND Leopard

**SP1632**

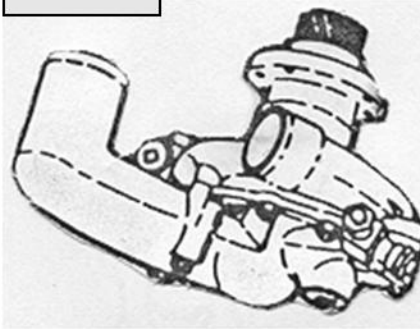

LEYLAND Bristol PSV

**SP1634**

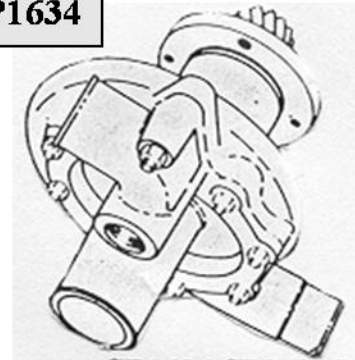

LEYLAND Tiger TL11

**SP1636**

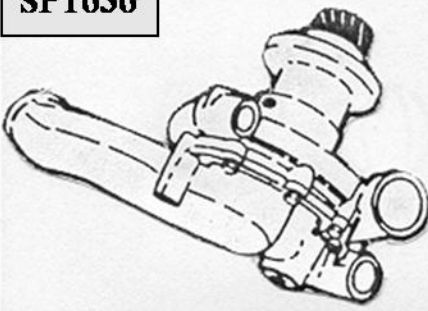

LEYLAND 680 PSV

**SP1638**



LEYLAND National 2

**SP1639**

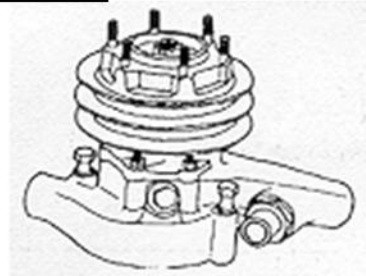

LEYLAND BRISTOL Very Early PSV Engine

## LEYLAND

**SP1640**

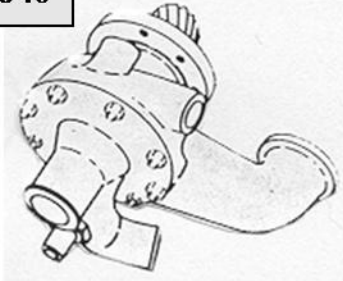

LEYLAND Bristol 401 Lynx O/Ring Fitting

**SP1641**

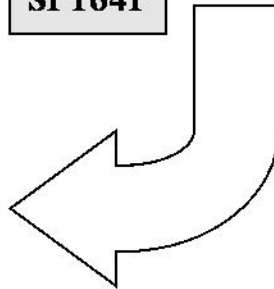

As left but  
With a  
hose pipe  
Outlet as  
opposed  
to an  
o-ring

LEYLAND Bristol 401 Lynx Pipe Fitting

**SP1644**

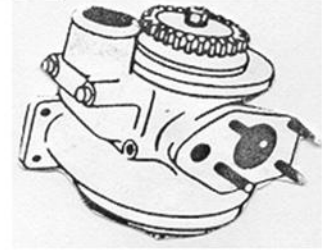

LEYLAND 501

**SP1646**

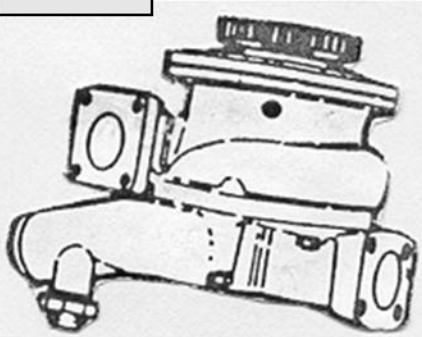

LEYLAND 510 National 1

**SP1647**

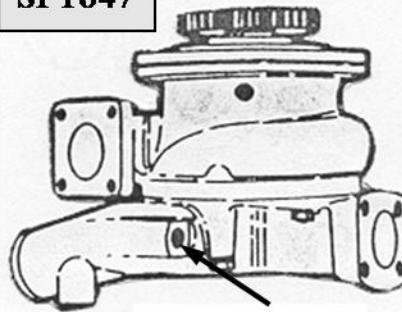

Threaded Hole

LEYLAND 510 With Threaded Hole in B/Plate

**SP1650**

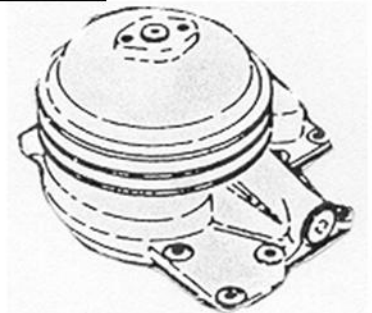

LEYLAND Atlantean + 2 Groove Pulley

**SP1651**

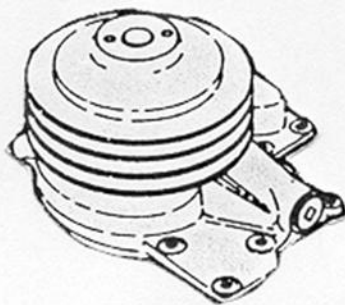

LEYLAND Atlantean + 3 Groove Pulley

**SP1652**

As right but with a  
2 Groove Pulley

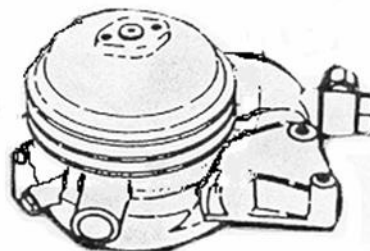

LEYLAND Early Atlantean + 2 Groove Pulley

**SP1653**

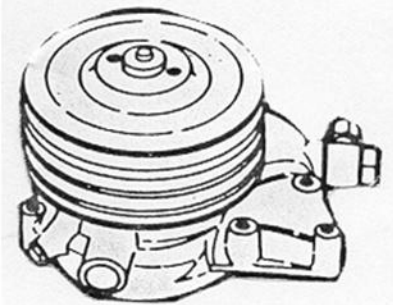

LEYLAND Early Atlantean + 3 Groove Pulley

**SP1655**

LEYLAND Fleetline + 2 Groove pulley

**SP1656**



LEYLAND Rationalised + 3 Groove Pulley